

DuROCK Uni-Track

EIFS Drainage Track

PRODUCT DESCRIPTION

DuROCK's patented **Uni-Track** is a PolyVinyl Chloride (PVC) extrusion designed to be used at horizontal terminations and at horizontal joints where DuROCK Exterior Insulation Finish Systems are expected to drain. Its one-size-fits-all profile eliminates the need to stock different profiles for every insulation thickness. DuROCK **Uni-Track** is three inches (76 mm) high, one inch (25 mm) wide, and ten feet (3.05 m) long. It is white in colour, but can be painted with most exterior latex paints.

INSTALLATION

DuROCK **Uni-Track** may be either embedded into the wet DuROCK Air/Moisture Barrier appropriate for the substrate or it may be mechanically fastened to the substrate with corrosion-resistant screws. Butt ends tightly together, and seal ends at termination points and at corners. Refer to the applicable EIF System specifications and details for more information.

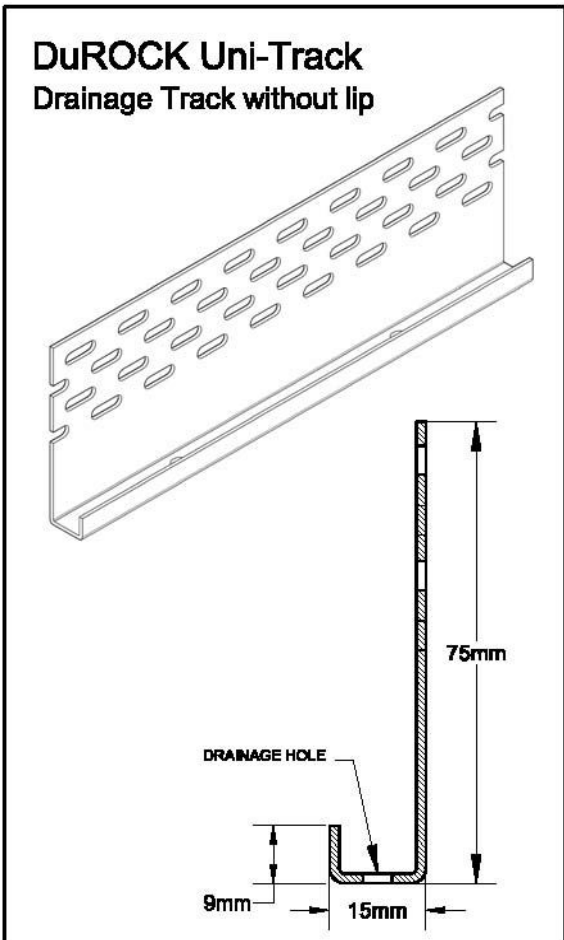
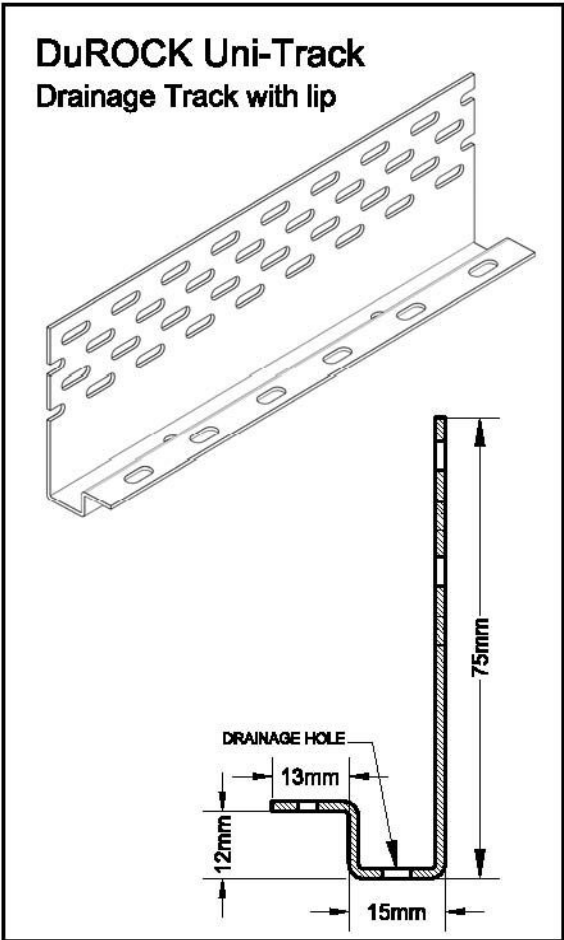

Refer to www.DuROCK.com for the most up-to-date version of this document.